

COMMON RULES OF DIZZY DEAN BASEBALL, INC.

All coaches and leagues must try to get rule interpretations and problems solved by their state and national officers before contacting the Commissioner's office. When a rule is not covered in these sections, refer to Official Baseball Rules Published by The Sporting News.

1:00 THE PLAYING FIELD

1:01 The playing field shall be regulation size for age group participating (See field layouts and Official Measurements). All other conditions are covered under Official Baseball Rules Published by The Sporting News.

1:02 Fence distances are recommended distance; see field layout section for proper age group. (See National State Executive Board for approval for tournament play if conditions are less.)

2:00 EQUIPMENT

2:01 All players must be in full baseball uniform (cap, numbered shirt, pants & socks). Team uniforms should be the same color. T-shirts (sleeves) of not more than two colors may be worn with the uniform. The Dizzy Dean patch must be attached in a manner not to appear temporary and be located in the same place on all jerseys (either sleeve or breast pocket). No other organization's patches, i.e., USSSA, NABA, etc., may be worn on a Dizzy Dean tournament teams uniform. In all district, state, and World Series, coaches must wear a full baseball uniform that matches and coordinates with their teams uniform as close as possible (not coaching shorts or trousers). PENALTY: Violators will not be allowed to participate. NOTE: All umpires must be in full uniform for tournament play. (No shorts allowed.)

2:02 A protective helmet with full ear flaps will be worn by all batters and base runners. A player refusing to wear a helmet, after being warned to do so by the umpire, will not be allowed to continue as a player in the game and shall be replaced by a substitute. The substitute will assume the ball and strike count if the player was a batter, or will take his position on the base he occupied if he was a base runner. It is recommended that all players wear athletic supporters. A catcher must wear a protective cup and a throat protector. For ages nine (9) and up, a catcher must wear a chest protector, shin-guards, protective cup, mask and a throat protector.

2:03 A player is not allowed to play any position or to bat without his shirt being tucked into his pants in the proper manner.

2:04 Players not in full uniform shall not be permitted to play in the game.

2:05 All uniforms must be same color for tournament play.

2:06 A number must appear on the back of the uniform shirt to assist the official scorer and spectators in identifying the players in tournament play. (Numbers not required on coaches shirts.)

2:07 The bat shall be a regulation baseball bat (not softball) (unaltered) made of either wood or an approved alloy.

2:08 Any player warming up the pitcher must wear a mask and a cup while in the down or crouch position.

2:09 A Dizzy Dean approved baseball signed by the commissioner should be used in all levels of play and must be used in all tournament play. (District, State and World Series)

2:10 Metal cleats will not be allowed for participants (coaches, players, and umpires) twelve (12) years and under.

2:11 A first (1st) baseman's mitt may be used by the first (1st) baseman and the catcher only.

2:12 Equipment must be kept in the dugout.

2:13 All casts, splints and braces must be padded. Any player equipment judged by the umpire to be unreasonably dangerous is illegal and cannot be worn.

3:00 RE-ENTRY SUBSTITUTION

3:01 Dizzy Dean Baseball is played under re-entry substitution in all local league and tournament play. Any starting player (pitcher included) may be removed from the game by being replaced legally with a substitute, and then returned to the lineup one time; however, he must be inserted in the same position in the batting order that he possessed at the start of the game. The starting player may return to the lineup at any time, on offense or on defense. This includes all games. Once the substitute has been removed from the game he cannot return. He can make only one appearance in the game. EXCEPTION: See Common Rules 3:03, and 7:06.

3:02 A batter removed from the game because of too many appearances on the field by the manager in one inning cannot return to the field until this half inning of play has been completed. Should this batter be a substitute player, he cannot return to the game at all, because a substitute can make only one appearance. EXCEPTION: See Common Rule 3:03.

3:03 If a manager or coach has used all of his eligible players and a player is injured, ejected, or becomes ill and cannot continue, the OPPOSING MANAGER must select one or more players on the bench who has already been in the game to replace the injured, ejected or ill player(s). If there is no one for the OPPOSING MANAGER to select, the game will be forfeited. A manager or player that is ejected must sit out the next game. Do not violate any pitching rules. In the event a team does not have the minimum number of players required the game will be forfeited.

3:04 When play is halted by officials for an injury, and a player is removed from the game, he will be declared an injured player and will not be allowed to return to the game. Only an eligible player may be used as a replacement for the injured player. WARNING: DO NOT VIOLATE ANY PITCHING RULES.

3:05 Under the re-entry substitution rule a pitcher may be replaced on the mound during any part of the game and return to the mound one (1) time. Example: A pitcher may pitch and be replaced with a substitute, and then return to the mound one time as a pitcher. See Common Rules 3:01 (Applies to same game only)

COMMON

4:00 MANAGER AND COACHES

4:01 A team may have a manager and (3) coaches as listed on your tournament team roster.

4:02 Two adults may coach the bases if they choose to do so. In all tournament play, District, State and World Series, coaches must wear a full baseball uniform that matches and coordinates with their team uniform. Coaches must wear a complete baseball uniform. (Not coaching shorts or trousers). (Numbers not required on coaches shirts.)

4:03 With the exception of the base coaches, all players, managers, etc. must remain in dugout, on benches, or prescribed areas throughout the game.

4:04 Only registered adult coaches and manager of the team are permitted on the coaching lines. The adult manager or coaches, whether or not they are on the coaching lines, may moderately dispute any decision or may discuss any point with the umpires to the extent allowed by the rules of professional baseball; however, if he at any time makes any derogatory remarks or undue criticism about or to the opposing players or umpire, he shall immediately be ejected from the game and sit out the next game.

4:05 The manager is responsible for the conduct of coaches, team and fans.

5:00 “See Appropriate Age Group Section” Regulation Games

6:00 “See Appropriate Age Group Section” Pitching Rules

6:01 Pitching changes must be reported to the home plate umpire who will announce the changes to the scorekeeper. Failure to do so will result in pitcher of record being charged with innings until notification or recognition of change has been made. Head coaches must check the pitching record for accuracy and sign immediately after the ball game.

6:02 An inning is interpreted to mean the following: If a pitcher pitches to one (1) batter and is removed from the pitching mound before he is retired, he is only charged with pitching 1/3 of an inning. If he is removed after retiring one (1) batter, but after he has pitched to the next batter, he is charged with two-thirds (2/3) of an inning. If he is removed after he has retired 2 batters and has pitched one (1) pitch to the next batter, he is charged with one (1) complete inning.

6:03 In all tournament play, pitching rosters must be signed within (10) ten minutes of the completion of play by both managers. If not, they will be signed by the tournament director and become official and cannot be altered.

6:04 When a pitcher is turned in on a line-up card he is the pitcher of record and must dispose of a batter before he can be replaced or substituted and he will be charged with a minimum of 1/3 of an inning. Any player who toes the rubber and takes a warm-up pitch to begin an inning will be the pitcher of record

for that inning and be charged with a minimum of 1/3 of an inning, and he must dispose of a batter (unless the pitcher is injured) before he can be replaced or substituted.

7:00 FORFEITURE, APPEALS & PROTEST

7:01 Should a question arise as to the interpretation of the playing rules, only the manager/head coach may appeal.

7:02 A team failing to field at least nine (9) uniformed players within fifteen minutes after the scheduled game time shall forfeit the game. A forfeit shall count in league standings. Teams dropping out of the league will have the results of their previous games discarded (League play only - See Tournament Section for tournament rules.)

7:03 A team that does not complete its schedule will not be allowed to put a player on the all-star team.

7:04 Playing illegal players or pitchers will result in forfeiture of games in which players or pitchers participate if protested by the opposing manager or coach. Should both teams use illegal players or pitchers both teams will be credited with a loss. A youth that is not an approved player on the playing roster is an illegal player. If a player belongs to another Dizzy Dean team or league and participates in a game in your league, he is illegal. A pitcher who has exceeded his allotted number of innings is illegal and the game will be forfeited if protested. If a manager or coach knowingly plays a player that is illegal after being told to stop by the local league, District Director, State Director or a National Director in that state, and continues playing that illegal player, that team and/or organization shall lose their franchise. You cannot back up into the tournament bracket past the last game played. In tournament play, only the last game played will be affected by forfeiture of the game.

7:05 An ineligible player is one who is legally a member of the team but who is ineligible to play or pitch in a particular game or games because of an infraction of the rules, or because of a previous violation or disciplinary action. It is the duty of the manager to keep a record of his players and pitchers.

7:06 The playing of an ineligible substitute will result in a protest if protested by the manager of the opposing team before the completion of the game. The penalty for the playing of an ineligible substitute will result in the replaying of the game from the point of the infraction if the protesting manager's team loses. (Refer to Common Rules 7:10 and 7:11)

7:07 A protest which involves an umpire's judgment may not be made. The only legal protest is one in which a violation of playing rules or the use of an ineligible player, or ineligible substitute, or an illegal player is protested. (Refer to Common Rules 7:10 and 7:11)

7:08 The protesting manager on a play situation must immediately notify the umpire that the game is being played under protest. Failure of the umpire to make this announcement shall not affect the validity of the protest. (Refer to Common Rules 7:10 and 7:11)

COMMON

7:09 A protest based on a play situation shall be considered only if it is placed in writing and submitted to the league president within forty-eight (48) hours. A fee set by local league may apply. **(In tournament play no protest fee will be required).** This fee will be returned if the committee rules in favor of the protesting party. The president shall appoint a committee of three (3) impartial managers or coaches from another league, if possible, to act as the protest committee.

7:10 Protest that are made in tournament play must be made to the umpire in chief (on the field) who will in turn refer the protest to the tournament director. The tournament director and umpire in chief (on the field) will then call the other members of the protest committee. The protest committee in tournament play shall consist of three (3) members as follows: (a) umpire in chief (or alternate umpire on the field if the umpire in chief made the call in question), (b) the District Director, the State Director or the National Commissioner or one person appointed by such at their respective tournament, (c) a third member associated with Dizzy Dean Baseball, Inc. but not connected with either team, this member to be appointed by "b" above or his representative. All other provisions of protest in tournament play to remain the same.

7:11 Tournament protests may be made only on a misinterpretation of a rule and ineligibility of a player or players. A protest based on the misinterpretation of a rule must be made before the next legal pitch. All other protests including ineligibility or legality of a player or players must be made before the team or umpires leave the playing field at completion of game. Protests must be made to the umpire in chief. The protest committee after hearing the protesting manager and the manager of the opposing team shall make a decision and that decision will be final. There will be no appeal. In all cases, a National Director or National Commissioner must be notified.

7:12 Rained out or otherwise postponed regularly scheduled league games must be played within seven (7) days, called by the league president. Failure to comply will result in forfeiture of the game by the home team, or they may appeal to the league president who will then set a time and date for play as nearly as possible to suit the convenience of both teams.

7:13 In local play only, a team may file a protest on the grounds of ineligibility of a player or pitcher within forty-eight (48) hours after the completion of the game. NOTE: According to the interpretation of this rule, only the game or games protested will be considered and all protests of this nature must be within forty-eight (48) hours. (For Tournament play see Common rule 7:11)

7:14 Any team manager or their adult leader who withdraws a baseball team from the playing field under any circumstances prior to the official completion of the game, or forfeits a game, shall forfeit all rights to protest as described in this section. He shall also forfeit this game by a score of 6 to 0 if 12 and under and 7 to 0 if 13 and up. If a team concedes a game before its completion, the score at that time will be the recorded score and stand as is or with a minimum score of 7 - 0 or 6 - 0 depending on age group involved. This with the consent of the tournament director. The pitcher will be charged with all innings actually pitched.

7:15 Any player playing for more than one Dizzy Dean franchised organization will be declared illegal.

7:16 No tournament game may be forfeited unless by a District, State, or National Director.

7:17 For appeals in T-ball, farm and minor league, see rule 7:18 in appropriate age group. For sophomore, junior and senior, see major league rule book.

8:00 SCHEDULES

8:01 A league is required to play a twelve (12) game schedule to qualify an all-star team for tournament play.

8:02 Leagues are encouraged to play an eighteen (18) game schedule, exclusive of exhibition and practice games when possible.

8:03 A team may play a double header, but for ages twelve (12) & under each game should be six (6) innings in length. Ages 13 and up should be seven (7) innings. (A time limit is acceptable in league play and should be included in league rules.)

8:04 Under no conditions can league officials set up a schedule of games which would require a team to play more than two (2) games in one day. A continued game of three (3) innings or less does not constitute a game.

8:05 Exhibition and practice games are permitted but all pitching rules must be followed.

8:06 Leagues may play an interlocking schedule.

8:07 Leagues should play at least two (2) scheduled games a week.

8:08 Teams that are in different congressional districts may play in the same leagues with another state if necessary. Also, communities that are located on state lines may play in a league with another state if necessary. Players playing in adjoining states must apply for release and be approved by both states on a boundary release form. See State or National Director for clarification.

9:00 SPECIAL RULES

9:01 No spectator shall be allowed on the playing field during the playing of any game. In the event that spectators swarm on the playing field during the playing of any game, the umpire in chief will request that the field be cleared by both managers within five (5) minutes under penalty of having the game forfeited.

9:02 No adult will be allowed on the playing field during the playing of any game without the consent of the umpires; and no persons except the officially registered players of the team, the manager and the coaches will be allowed on the bench or in the dugout during the playing of any contest.

9:03 At least two (2) umpires shall be furnished for each game. You may use more if they are available. All officials for District, State, and World Series play must be at least 19 years old unless approved by the National State Executive Board.

COMMON

9:04 A baseball player, manager, coach, umpire or game official, will not be allowed to use tobacco products, alcohol or profanity during the ballgame. If, in the opinion of the umpires, a player or manager or coach or scorekeeper conducts himself in an unsportsmanlike manner or commits any act which may maim or injure an opposing player, if deemed deliberate, he shall be ejected from the game. When a manager, coach, or player is ejected, he must leave the dugout or bench and sit out that game and the next scheduled game. The tournament director shall have the authority to remove any manager, coach or player for the remainder of the tournament for any flagrant unsportsmanlike conduct.

9:05 No manager, player, substitute, or coach shall at any time, whether from the bench, the coaches box or on the playing field or elsewhere—

- (a) Incite or try to incite by word or sign a demonstration by spectators.
- (b) Use language which will in any manner refer to or reflect upon opposing players, an umpire or any spectator.
- (c) Call “time” or employ any word or phrase or commit any act while the ball is alive and in play for the obvious purpose of trying to make the pitcher commit a balk.

9:06 In league play all ground rules must be given on paper to the visiting manager and coach. Only those rules will be honored. You cannot make up ground rules as the game progresses. These ground rules must be filed with the league president before the schedule begins.

9:07 In tournament play all ground rules will be covered and agreed upon between coaches and umpires before each game.

9:08 The home club must have their pitcher warmed up and ready to pitch after eight (8) warm up pitches, or two (2) minutes, immediately after the umpire notifies the teams to play ball.

9:09 Any runner is out when he does not slide or attempt to avoid the fielder who has the ball in the proximity of the base and is waiting to make the tag, or if he maliciously runs into a fielder.

9:10 No artificial noisemakers allowed. Penalty: Offender will be removed after one (1) warning.

9:11 The host team will furnish trophies for all State and World Series Tournaments: A first place individual trophy being a minimum of 8” tall; a second place individual trophy being a minimum of 6” tall; a third place individual trophy or medallion and a sportsmanship trophy must be awarded. It is recommended that a first, second and third place team trophy be furnished.

9:12 All members of an all-star team nine (9) and under will receive a trophy or certificate for State and World Series Tournament.

9:13 The infield fly rule is in effect for ages nine (9) and above.

9:14 Any manager, coach or player that is ejected must sit out the next game. See common rule 7:04.

10:00 TEAMS

10:01 Teams that are now operating under another organizational name that come into the Dizzy Dean Baseball program shall be allowed to retain their eligible players who were on the team roster the year before. The only change you have to make to convert the team into Dizzy Dean Baseball is to make application for a franchise and be approved, providing they have complied with all player selection rules and are approved by the National State Executive Board.

10:02 Communities wishing to franchise one league and one all-star team 5 thru 19 may do so with the approval of the State Director and National State Executive Board.

10:03 Once a player is on a team roster he is not allowed to transfer from team to team, league to league, or district to district without a written release. This must be approved by the State Director and the National State Executive Board (see common rule 15:05).

11:00 ALL-STAR TOURNAMENT TEAMS

11:01 A player must be a member of a franchised Dizzy Dean team and participate in at least one half of that team's scheduled games to be eligible for the all-star team. Violation of this rule will make such all-star team ineligible. Managers are requested to double check player eligibility. EXCEPTION: A player injured in play after becoming a member of the team that is forced to miss more than half of the games will be eligible for the all-star team provided it is agreeable with all the managers involved in the selection of the team, with the approval of National State Executive Board.

11:02 Each team should have at least one player on the all-star team. It is recommended that the winning manager of the league manage the all-star team and choose his coaches and the remaining players he desires to fill out his roster.

11:03 Eighteen (18) players ages 5 and up are allowed. Once a player has been named to the all-star team, he cannot be replaced unless he becomes sick, injured or moves away. Replacement players will be allowed between tournaments to fill roster to original number of players using criteria as set forth in the rule book for player selection. National State Executive Board or National Commissioner must approve all replacement players.

11:04 An organization with fewer than eight (8) teams may have one (1) or more all-star teams with the approval of the National State Executive Board or the National Commissioner. Leagues with more than eight (8) teams must have two (2) or more all-star teams.

11:05 Leagues of less than four (4) teams that have been approved by the State Director and the National State Executive Board may select an all-star team.

11:06 A league may enter an all-star team or league winner in tournament play.

COMMON

11:07 No player may be selected for more than one (1) Dizzy Dean Tournament team.

11:08 A player or team cannot participate in two (2) tournaments at the same time. This means Dizzy Dean and Babe Ruth, Pony, Dixie Youth, AABC, etc...

11:09 A player cannot participate in another tournament after the Dizzy Dean Tournament starts. A player must be available to play on each day of the tournament unless approved by the tournament director, and may not participate in any other organizational tournament (Babe Ruth, Pony, Dixie Youth, AABC, etc) unless his options to advance in the Dizzy Dean program have been completed. NOTE: DO NOT VIOLATE ANY PITCHING RULE.

11:10 No team may have a bat boy.

11:11 Any player who misses any scheduled league game to play on a pick-up or tournament team before league play ends will not be eligible for all-star play.

11:12 Any league or organization that ends their season play prior to June 1st will not be eligible for tournament play (this can be changed only by the National State Executive Board with approval of the Commissioner of Dizzy Dean Baseball) but never prior to May 15.

11:13 Requirements: Teams participating in a Dizzy Dean World Series:

- A. Proof of Birth
- B. Proof of Insurance
- C. A Medical Release Form
- D. Team Photo: All names written on back of the photo.
Identify each person as they appear on the front from left to right.
- E. Scorebooks from the State Tournament.
- F. Your Yellow Team Roster (properly signed).
- G. Your World Series Entry Form properly signed.

11:14 Teams who do not field enough players for a tournament game will be ruled as abandoning the tournament and shall no longer be eligible for additional tournaments. i.e., if you drop out of District Tournament play, you will be ineligible for State or World Series play. If you drop out of state tournament play, you are not eligible for World Series play. This includes pool play. You must complete every tournament game you enter. See Common Rule 7:14 Refer to Common Rule 7:16.

11:15 Once a player is named to the tournament team/all-star team he cannot be replaced unless he becomes sick, injured or moves away once a tournament starts. A player who simply quits the team cannot be replaced. Replacement players will be allowed between tournaments to fill roster to the original number of players using the criteria as set forth in the rules for player selection. The National State Executive Board or National Commissioner must approve all replacement players.

11:16 A team that fails to fulfill its obligation to the tournament, (i.e. opening ceremonies, pool play, consolation bracket, etc.) will be forfeited out of the tournament and appearance fee will not be refunded. See Common Rule 11:14. Refer to Common Rule 7:16.

11:17 Teams who do not field enough players for a tournament game in pool play will be ruled as abandoning the tournament and all their games will be scored 1 to 0. Refer to Common Rule 7:16.

11:18 All teams including the host must qualify in pool play to advance to the championship bracket.

11:19 In any pool play winner will be determined by:

Best Record • Head to Head Competition

Runs Allowed • Runs Differential

Runs Scored • Coin Toss

Note: Names on the tournament and World Series roster must be the same as they are on the proof of birth.

12:00 PLAYER ELIGIBILITY

12:01 Dizzy Dean Baseball, Inc. for a player's age group shall be open to any approved youth whose birthday falls before May 1st (August 1st for 18/19) of the current year. A player may play up one age group in local or tournament play. He cannot play down in tournament play. EXAMPLE: An 11 or 12 year old can play with a 13 or 14-year-old team. If an eleven (11) year old plays in a twelve (12) year old league, he may not drop down and play as an eleven (11) year old all-star. This does not count for mixed leagues of 9 and 10 or 11 and 12 or 13 and 14 or for 15-16-17-18-19 ages.

12:02 Only approved youth who are amateurs are eligible for Dizzy Dean Baseball Competition.

12:03 Amateur is defined here to be in accordance with the rules of the high school athletic association. NOTE: District presidents or managers in doubt of violating the amateur status of a player are cautioned to contact their state high school athletic association to ascertain its ruling or policy which would affect the athlete.

13:00 BIRTH CERTIFICATES

13:01 Dates of birth shall be certified by birth certificate or other legally accepted proof of age to a league official (president) prior to the league's first regularly scheduled game. A legible copy of a birth record will be accepted, provided it is stamped and notarized as a true copy of same, signed by one or both of the parents of the player. This requirement will not be necessary if the birth record is a certified copy and was issued by the state, county parish, or United States Government. A valid drivers license is an acceptable proof of age.

13:02 Players not legally adopted but using a name different from that which appears on the certificate will be eligible provided that a notarized statement of this fact is made before a probate judge or clerk of court and statement attached to the birth certificate with the signature and seal of the probate judge or clerk of court.

13:03 Managers of teams participating in tournament play must have in their

COMMON

possession at all times proof of date of birth as stated above. These records are to be inspected by a credentials committee appointed by the tournament director prior to the tournament. These records are to be presented at all tournaments.

14:00 PLAYER REGISTRATION

14:01 All leagues participating in tournament play are required to file a roster of players of each team in each league with the league president and state director on or before May twentieth (20th) for players 5 through 12 years of age.

14:02 All leagues participating in tournament play are required to file a roster of players of each team in each league with the league president and state director on or before June first (1st) for Sophomores, Juniors and Seniors.

14:03 The full name of the player, his date of birth, residence by street, road, etc., shall be included in the registration.

14:04 Unless you are the host team for a Dizzy Dean World Series, you must complete a Dizzy Dean ONLY State Tournament to be eligible for Dizzy Dean World Series play. (See Common rule 7:15)

14:05 Communities or playgrounds participating in Dizzy Dean Baseball must sanction all teams in each age group that they choose to participate in. EXAMPLE: If a community or playground would have enough youths to have five (5) teams of 15-16 year old players, they must sanction all five (5) teams. Violation of this rule could result in the loss of your franchise.

15:00 SELECTION OF PLAYERS

15:01 The National State Executive Board will determine league boundaries from which to select players. When two or more leagues operate within a certain locale, they may select players from combined areas by agreement of the officials involved, but all managers must have equal opportunity in selecting of the players. Recommendation: Each year all players selected to a team (with the exception of manager's child and one (1) assistant) must be drafted, meaning all managers in an organization shall have equal rights and opportunity to select any player in that organization. If the organization has multiple leagues (i.e. American, National, Continental, etc.), all managers must draft from the same player pool at the same time and divide into leagues after the selection process.

15:02 The National Board of Directors of Dizzy Dean Baseball, Inc. reserves the right to continue as a player any youth (1) whose residence changes after becoming a member of a team in a league or (2) who lives outside the league's boundaries even if the youth then resides in the territory of another league.

15:03 Each league with the approval of the State Director and the National State Executive Board shall determine its own system of selection of players. (Refer to Common Rule 15:01)

15:04 In the rural areas where four (4) or more small communities come together to form a league, the players within a ten (10) mile area belong to that league. All players outside this area are free players and can play with whatever team they choose.

15:05 All players ages 12 & under, who change franchised Dizzy Dean Base-

ball, Inc. organizations without changing their legal residence, if the original organization offers their age group, will be ineligible for tournament play for one (1) year. In all cases including changing their legal residence, the National State Executive Board of the state in which you reside, must approve this. Refer to Common Rule 7:04.

16:00 LEAGUE REGISTRATION

16:01 Leagues affiliating themselves with this program must mail an **Application for sanction** with two (2) additional copies to your state director by May 20th (ages 5-12) and June 1st (ages 13-19 and High School). A **Team Certificate of Entry** must be sent to the state director for each team in your league. The **Team Certificate of Entry** must match the league's as submitted on your **Application for Sanction**. A **Team Roster** must be in the office of the state director one (1) week prior to your first (1st) tournament (District or State). All players on the **Tournament Team Roster** must have been listed on a previously submitted **Team Certificate of Entry**.

16:02 The state director must mail one (1) copy of the **Application for Sanction** and one (1) copy of the **Team Certificate of Entry** to the state secretary and the national commissioner. The state director must retain a copy of the **Application for Sanction**, the **Team Certificate of Entry** and the **League's Schedule** and make them readily available upon request to the national commissioner or any Dizzy Dean Tournament Director.

16:03 The state secretary must mail two (2) copies of the **Application for Sanction** with the proper fees to the national treasurer.

17:00 TEAM SPONSORS

17:01 Dizzy Dean Baseball teams should be sponsored only by those organizations, firms or companies whose activities or products are not detrimental to the welfare of the youth.

18:00 ADMISSION TO GAMES

18:01 In order to help defray expenses of winning teams competing in tournaments, it is recommended that admission be charged in all tournaments and championship series.

19:00 TOURNAMENTS

19:01 In tournament play a pitcher may not pitch more than his maximum number of tournament innings. Once he has, he cannot pitch again until he has had his required rest. (He becomes an illegal pitcher once he has exceeded his maximum number of innings.) Do not violate any pitching rules.

19:02 Tournament protests are covered in Section 7:00 common rules.

19:03 All-star teams may have eighteen (18) players, one (1) manager and three (3) coaches on the team. See rule 11:27 for Farm League. EXCEPTION: High School has twenty-four (24) players.

19:04 All teams participating in tournament play will be required to wear the Dizzy Dean Patch attached in a manner not to appear temporary and located in the same place on all jerseys (either shoulder or breast pocket). A number must

COMMON

appear on the back of the players jersey. (Not coaches) PENALTY: Violators will not be allowed to play.

19:05 Each team entering a draw for a tournament slot must deposit \$250.00. This will be returned after the team is eliminated from the tournament. Exception: High School Division World Series. (See High School Tournament Rules Format).

19:06 Tournament affidavits must be filled out by all teams participating in tournament play. This affidavit will include name, date of birth, age, address of the players and the name of player's team.

19:07 Each team must have two (5x7) team photographs with the player's names written across the back left to right as they appear in the photograph. A team photograph and a team roster of the state tournament team must be turned in to the state director on the opening day of the state tournament. There will be no changes to the roster after the tournament begins. The manager will keep the other photograph. The state director will make arrangements to have team's picture taken if they arrive at the state tournament without their photograph. State tournament directors will mail a team photograph and a team roster of all teams in their tournament to the World Series tournament director on the opening day of the state tournament. As soon as a winner is certain in each state, the state director will telephone, collect, the World Series tournament director and notify him of the winner. This will not cause delay in having that team's picture in the program. This will save much time on the part of the program committee.

19:08 Teams participating in tournament play must have a proof of birth, as stated under common rule 13:00 Birth Certificates, in their possession. These records are to be inspected by a credentials committee. These records are to be presented at all tournaments at the request of the tournament director. Scorebooks from the state tournament will be sent to the World Series tournament director by the state director.

19:09 Once a team has been certified as being eligible for tournament play, the team as well as individual players can be questioned and they may be disqualified if in violation of any rule governing Dizzy Dean Baseball.

19:10 No team will be required to play more than two (2) games in the same day during the same tournament. EXCEPTION: A continued game of three innings or less will not constitute a game. For Farm League see Farm League section.

19:11 It is the duty of the manager to keep a record of eligible players and pitchers.

19:12 Beginning with the district tournament, all levels of tournament play must use an approved Dizzy Dean Baseball signed by the commissioner.

19:13 Pitching rules listed in common Section 6:00 and 7:00 will apply in tournament play.

19:14 Tournaments may be single, double elimination or 3 game guarantee. This is left up to each district, state tournament director with the approval of the National State Executive Board. The Dizzy Dean World Series will be double elimination or 3 game guarantee. Use the winner's bracket for single elimination tournaments. Exception: See rule 9:14 in Farm League and Minor League.

19:15 If a state has only one (1) league, that league will be the state champion. If there are two (2) leagues only, these teams will play a best two out of three series.

19:16 All teams participating in tournament play must provide evidence of the following insurance policies: 1) Excess Accident Insurance with a medical limit of at least \$50,000. It is not acceptable for each parent to provide individual

evidence of health insurance for his or her child. 2) General Liability Insurance with an "each occurrence" limit of at least \$1,000,000 combined single limits for "bodily injury" and "property damage". Such policy may not provide "claims made" coverage and may not have an exclusion for lawsuits arising out of injuries to athletic participants. If a team does not purchase its General Liability insurance through the endorsed Dizzy Dean insurance plan (see rulebook ad), it is required that the team's General Liability policy be endorsed to name Dizzy Dean Baseball, Inc. as an "Additional Insured".

19:17 Official tournament brackets of Dizzy Dean Brackets must be used either double-elimination or 3 game guarantee.

19:18 All teams will draw for position in tournament play. The host team will have the choice of the game time on opening day only. Every effort to avoid 1st round play of teams from same league should be made and if it is a National Tournament, same state teams should be avoided.

19:19 All official scorebooks will be collected after each world series and sent with a picture of the championship team to the secretary or treasurer of Dizzy Dean Baseball.

19:20 The HOST team for the STATE TOURNAMENT will be allowed to participate in the district tournament.

OFFICIAL MEASUREMENTS

Division	Bases	Pitching	Recommended Fence Distance	
			Min	Max
5-6 T-Ball	50'	39'	120'	140'
5-8 Farm League	60'	46'	140'	200'
9-10 Minor	60'	44'	200'	250'
11-12 Freshmen	70'	49'	200'	250'
13-14 Sophomore	80'	54'	250'	300'
15-16 Junior	90'	60'6"	300'	
17-18 Senior	90'	60'6"	300'	

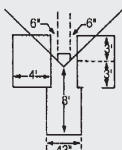

CATCHER'S BOX AND BATTERS' BOXES

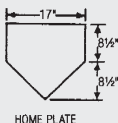

HOME PLATE

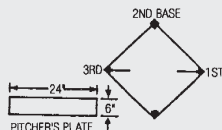

PITCHER'S PLATE

T-BALL

T-BALL LEAGUE - 5-6 YEARS OLD

OPTIONAL: TO BE USED IN LOCAL LEAGUE PLAY

The "T-Ball" division of Dizzy Dean Baseball, Inc. has been organized as a baseball program for ages 5-6 and designed to have the ball hit off a tee.

PLAYER ELIGIBILITY

Dizzy Dean Baseball, Inc. "T-Ball" ages 5 or 6 shall be open to any approved youth, regardless of sex, color, religion or race, whose 5th and 6th birthday falls before May 1st of the current year.

1:00 PLAYING FIELD

1:03 The coaches box is to be a minimum of three (3) feet wide and six feet long and no closer than six (6) feet to the base path.

1:04 The pitching rubber is thirty-nine (39) feet from the back point of home plate to the front of the pitching rubber.

1:05 There will be a twenty (20) foot chalked arc from the first (1st) base line to the third (3rd) base line drawn from the back point of home plate. The ball must be on or past this line to be fair. If not, it will be a foul ball. The ball is fair if it is hit inside the arc and travels beyond the arc line. If the ball is missed completely, but still comes past the arc, because of the striking of the tee, it will be a strike.

1:06 Forty (40) foot lines will be drawn on the foul lines between home and first (1st) and between home and third (3rd). Infielders must stay behind these lines until the ball is hit. **PENALTY:** Offensive team gets choice of the play or re-bat.

1:07 The playing field should be a recommended minimum distance of 120 feet and a maximum of 140 feet.

1:08 The base paths will be fifty (50) feet.

1:09 Batters' boxes will be drawn three (3) foot wide and six (6) foot long and positioned four (4) inches from the edge of the plate. There should be three (3) feet in front and three (3) feet in back of the middle of home plate.

1:10 There will be a four (4) foot line drawn ten (10) feet on the second (2nd) base side of first (1st) base, third (3rd) base side of second (2nd), and home plate side of third (3rd) base to be used by the umpires in determining when time should be called.

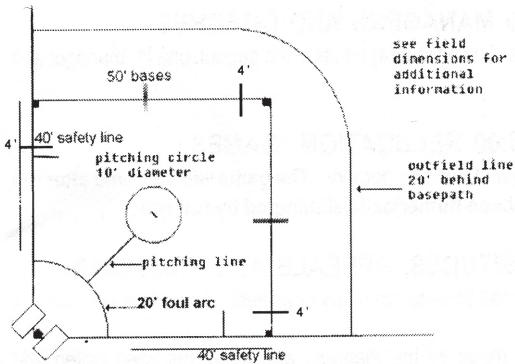

2:00 EQUIPMENT

2:13 Tennis shoes or baseball shoes with RUBBERIZED cleats may be worn.

No Metal or Plastic Cleats. Shirts must be tucked in.

2:14 All batters and runners must wear batting helmets. Chin straps must be worn with all types of helmets. Any player running the bases and deliberately removing his headgear (in the umpire's judgment) should be given a warning and on any subsequent offense will be called out. Wrap around types may be used but must have a crown protective insert and chin strap.

2:15 Catcher must wear a helmet.

2:16 Approved batting tees (unaltered) will be provided by each team.

2:17 Approved helmets meeting safety requirements will be furnished by each team.

3:00 RE-ENTRY SUBSTITUTION

3:05 If a manager has used all of his eligible players and a player is injured, becomes too sick to continue, or is ejected, the game will not be forfeited. In the case of an injured or sick player, the OPPOSING MANAGER must select as a replacement one of the players on the bench who has already been in the game. In the case of an ejected player, he shall simply be scratched from the lineup and the team will play with a player short. No team shall play with less than eight (8) players in **league play**. No out shall be charged when that player would have batted. An injured player who has been replaced cannot return to the game.

3:06 Substitutes should be announced by the official scorekeeper, but failure to do so will not make the substitute illegal. Substitutes will be considered in the game according to the substitute rules of Dizzy Dean Baseball and the rules of regular baseball.

T-BALL

4:00 MANAGERS AND COACHES

4:06 Each team will be allowed four (4) adults in the dugout, one (1) manager and three (3) coaches.

5:00 REGULATION GAMES

5:03 A game will be four (4) innings in duration. The game will be called after the opposing team has been numerically eliminated by run rule.

7:00 FORFEITURES, APPEALS AND PROTESTS

7:17 The umpire may call time-out for injury or protest. These time-outs will not be charged to a team.

7:18 Appeals will be made by the manager after time has been called and before the ball is returned to the tee by the home plate umpire. The coach will notify the umpire involved of his appeal of what runner and what base. NOTE: For the purpose of the appeal play, returning the ball to the tee by the home plate umpire will be the same result as the next pitch being thrown.

9:00 SPECIAL RULES

9:12 If a player is injured by being hit with a batted ball in the face, throat, or head, time will be called immediately and all players will be awarded one (1) base if injury is to an infielder, two (2) bases if injury is to an outfielder. The awards are from the time of the pitch. Any other injury, deemed serious enough in the judgment of the umpire, will be handled in the same manner. Note: This is a judgment call and cannot be appealed or protested.

10:00 TEAMS

10:04 All ages 5 thru 8 will be allowed eighteen (18) players whose names shall be registered with the league president by May 20th on league roster forms.

11:00 ALL-STAR TOURNAMENTS TEAM TOURNAMENTS

11:21 In all World Series and tournament play, in order for a game to become a complete game, it must be a full four (4) inning contest, regardless of the delay; and no other tournament game can be started until the completion of the interrupted game. All games shall be four (4) innings duration, unless the losing manager wishes to concede without penalty. Exception; A game will be called when the opposing team has been numerically eliminated. This rule to apply in all local league play and all tournament play.

11:22 Teams may play more than two (2) games in one (1) day with the approval

of the Dizzy Dean National State Executive Board.

11:23 Age verification will be shown at the credentials meeting prior to all tournaments. Players may not be seven (7) years old prior to May 1st of that year.

20:00 OFFENSE

20:01 After one (1) warning per game per player for slinging his bat, the batter will be called out for each additional time that he slings his bat.

20:02 The batting order shall consist of nine (9) batters. The offense will have three outs or bat nine (9) batters per inning. No batter shall bat twice in one (1) inning. (Unless a batting out of order occurs.)

20:03 Base coaches shall remain in their coaching boxes at all times unless playing dictates otherwise. There may be a batting coach behind home plate in the designated area. Batting coaches may position the batter and adjust the tee one (1) time for each batter. PENALTY: Batter is out if coach resets the tee or batter.

20:04 The tee will be removed by the umpire after each batter.

20:05 Four (4) innings is a complete game. The game will be called after the opposing team has been numerically eliminated by run rule.

20:06 Batter is out if he touches the ball that is declared a foul ball or a dead ball.

20:07 Bumping the ball off the tee during warm-up is not a strike and will be called a no-pitch by the home plate umpire.

20:08 The batter will receive three (3) strikes before being called out. Any of the following will result in a strike being called on the batter.

A. In the judgment of the umpire the batter misses the ball completely.

B. The batter fails to hit the ball past the twenty (20) foot arc on the first (1st) and second (2nd) hit resulting in the ball being called foul.

C. Any foul ball before the third (3rd) strike.

20:09 Any ball struck and carried on or past the twenty (20) foot arc shall be a fair ball if the ball is touched in fair territory or passes first (1st) or third (3rd) before going foul even though part of the tee may have been struck. NOTE: Any ball in the judgment of the umpire that carries past the twenty (20) foot arc but was not touched by the batter's bat will be called a strike.

20:10 NO BUNTING will be allowed. Half-swings as judged by the umpire, will be called a bunt. PENALTY: A strike will be called on the batter. If on the third (3rd) strike, the batter will be called out.

20:11 It is not an out in T-Ball play for batter stepping on home plate. Delay dead ball and defense gets choice of play or re-bat.

20:12 If the runner leaves the base before the ball is hit, he will be called out.

20:13 Any offensive coach physically assisting a base runner while the ball is in play will result in that runner being called out.

20:14 Offensive team may have one (1) time out per batter, but cannot reset the batter or the tee during this timeout.

20:15 The batter may adjust his tee himself, if he so decides, or the batting coach

may ask the home plate umpire to adjust the tee for the batter with no penalty.

20:16 There will automatically be two (2) outs when the ninth (9th) batter comes to the plate. Any out made will be considered the third (3rd) out of the inning.

NOTE: The offensive team or scorekeeper must notify the umpire when the ninth (9th) batter comes to bat and the umpire shall notify the defensive team.

PENALTY: The defensive team gets the choice of the play or rebat

21:00 DEFENSE

21:01 NO ROLLING of the ball intentionally will be allowed. No outs will be allowed by rolling the ball. Runners will automatically be safe if defensive team rolls the ball. (Umpires decision)

21:02 The infield fly rule will not be in effect.

21:03 There will be nine (9) players on defense. There will be five (5) infielders that must remain in the infield until the ball is hit. Outfielders must remain twenty (20) feet behind the base lines until the ball is hit. **PENALTY:** The offensive team gets a choice of the play or re-bat.

21:04 The pitcher must have one (1) foot in contact with the rubber when the ball is hit. **PENALTY:** The offensive team gets the choice of the play or re-bat.

21:05 Time is automatically called by the umpire when the lead runner is faced off and/or forced into the ten (10) foot designated line at the base. **NOTE:** The umpire should not be too quick to call time. If the lead runner is not faced off, the umpire should allow the offensive coach time to react to the situation and run his runners if he decides.

21:06 Overthrows inside the fence will be a live ball and allow the base runner as many bases as possible. Overthrows outside the field of play will be declared a dead ball and bases awarded under the rules of regular baseball.

21:07 If a catcher is not used, he can be used as a fourth (4th) outfielder. If a catcher is used, he must wear a protective helmet but not the full catcher's outfit.

21:08 A caught fly ball will be played the same as regular baseball and play is not dead unless the ball is hit by the ninth (9th) batter of the inning.

21:09 One defensive coach may be out of the dugout at the open end to instruct his defensive players. **OPTION:** The defensive team may have a defensive coach on the first (1st) base foul line and third (3rd) base foul line thirty (30) feet from the base path and six (6) feet of the foul line.

21:10 The defensive catcher must be in a direct line 10 feet behind home plate to make a play on a batted ball. **PENALTY:** Offensive team gets a choice of play or rebat.

FARM LEAGUE 5-8 YEARS OLD

All coaches and leagues must try to get rule interpretations and problems solved by their state and national officers before contacting the Commissioners Office.

The Farm League Division of Dizzy Dean Baseball, Inc. has been organized as a baseball program for youth whose 5th, 6th, 7th or 8th birthday falls before May first (1st) of the current year. Rules set forth in this book shall govern all tournament play. It is suggested that individual leagues follow these rules in local league play; however, they may be adapted to fit local league play at the option of each individual league.

Six (6) year olds and under may play coach pitch or bat off "T". Six (6), Seven (7) and Eight (8) year old farm league will play coach pitch in tournaments. Call your state director for clarification of any rule not covered in this book.

1:00 PLAYING FIELD

1:03 The coaches box is to be a minimum of 3 feet wide and 6 feet long and no closer than 3 feet to the base path.

1:04 The pitching circle will be ten (10) feet in diameter and the center will be forty-six (46) feet from the back of home plate.

1:05 There will be a twenty (20) foot chalked arc from the first (1st) base line to the third (3rd) base line in front of home plate. The ball must be on or past this line to be fair if not, a foul ball.

1:06 Halfway/safety hash-mark (30) feet will be drawn on first baseline and third baseline in front of home plate. Infielders must stay behind this 30' hashmark until ball is hit.

PENALTY: Offensive manager gets choice of result of play or re-pitch.

1:07 Recommended minimum homerun distance will be 140 feet.

1:08 The base paths will be sixtv (60) feet.

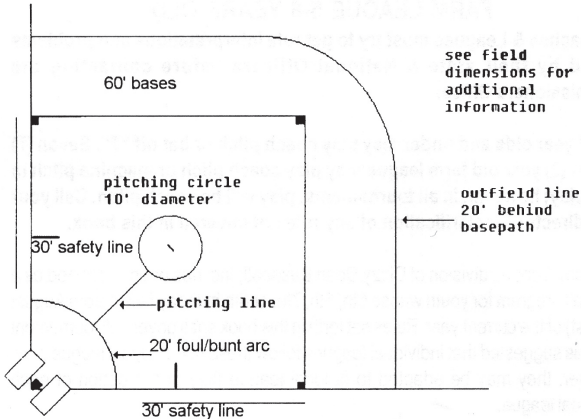

FARM LEAGUE

2:00 EQUIPMENT

2:13 Tennis shoes or baseball shoes with RUBBERIZED cleats may be worn. NO METAL OR PLASTIC CLEATS.

2:14 All batters and runners must wear batting helmets with a chin strap. Any batter who steps into the batters box without his headgear is awarded a strike. Any player running the bases who deliberately removes his headgear (includes chin strap), in umpire's decision, is out. EXCEPTION: Home run over the fence or time out.

2:15 Catcher must wear face guard and helmet. Chinstrap is not required.

3:00 RE-ENTRY SUBSTITUTION

3:05 In league play if a manager has used all of his eligible players and a player is injured, becomes too sick to continue or is ejected, the game will not be forfeited. In the case of an injured or sick player, the OPPOSING MANAGER must select as a replacement one of the players on the bench who has already been in the game. In the case of an ejected player, he shall simply be scratched from the lineup and the team will play with a player short. No team shall play with less than eight (8) players in league play. No out shall be charged when that player would have batted. An injured player who has been replaced cannot return to the game.

3:07 Dizzy Dean Baseball is played under re-entry substitution in all local league and all tournament play. Any starting player may be removed from the game by being replaced legally with a substitute and then return to the lineup one (1) time; however, he must be inserted in the same position in the batting order that he possessed at the start of the game. The starting player may return to the lineup at any time, on offense or defense. This includes all games. Once the substitute has been removed from the game, he cannot return. He can make only one appearance in the game. EXCEPTION: If a manager has used all of his eligible players and a player is ejected, injured, or becomes ill and cannot continue, then the OPPOSING MANAGER must select one or more of the players on the bench who have already been in the game to replace the ill or injured player or players. This only applies to a substitute and not an ejected player. If there is no one for the opposing manager to select, then the game will be forfeited. An injured player who has been replaced cannot return to the game. No team shall play with less than eight (8) players in league play.

4:00 MANAGER AND COACHES

4:06 Each team will be allowed four (4) adults in the dugout, one (1) manager and three (3) coaches.

5:00 REGULATION GAMES

5:03 A game will be six (6) innings in duration. The game will be called after the opposing team has been numerically eliminated by the run rule.

5:04 There will be a maximum of one offensive and one defensive time out per inning with each time out being no more than one (1) minute in length. The score-keeper will keep a log of time-outs. PENALTY: For a defensive violation you will remove the player pitcher. For an offensive violation you will change the batter. Player may re-enter without violating substitution rule at the completion of the inning. **DO NO VIOLATE ANY SUBSTITUTION RULE.**

5:05 Any game called for bad weather after three (3) complete innings will be considered a complete game. If interrupted before three completed innings the game will be rescheduled at the point of interruption. Tournament play will be six (6) full innings always.

6:00 PITCHING RULES COACH PITCH

6:17 An offensive coach will pitch to his own batters. The coach may only coach the batter until he reaches first (1st) base or after he leaves third (3rd) base. The coach will be replaced after one warning of a violation. See rule 4:03 Common Rules.

6:18 The pitcher may pitch anywhere from in front of the 20 foot foul arc to the pitching circle. He may not cross the foul line or enter the pitching circle. He must keep one foot on or astraddle the pitching-line. The coach may pitch over-handed or underhand to the 6 & 7 year olds. He must pitch overhand to the 8 year olds. PENALTY: For not standing on or astraddle the pitching-line the defensive team gets the choice of the play or re-bat.

6:19 Any batted ball that hits the pitching coach will be a dead ball and a no pitch. If the pitching coach intentionally (in the umpires judgment) allows the ball to hit him, the batter will be out and a dead ball called. No runner may advance.

6:20 The offensive coach (pitcher) must attempt to leave the field and try to pick up the batter's bat. The offensive coach (pitcher) that does not attempt to get off the field and interferes with the defensive player to keep him from making a play will cause the batter to be out. No runners advance.

6:21 Teams may play more than two games in one day with the approval of the Dizzy Dean National State Executive Board.

7:00 FORFEITURES, APPEALS AND PROTESTS

7:17 The umpire may call time-out for injury or protest. These time-outs will not be charged to a team.

7:18 An appeal play will be handled in this manner. The manager will make his appeal to the plate umpire who will consult the base umpire. The manager must identify the correct player by name or number and also the correct base involved in the play, no second chance if he names the wrong player or base. If he is correct, the base runner is out. Appeal must be made before the next pitch is thrown.

9:00 SPECIAL RULES

9:06 In league play all ground rules must be given on paper to the visiting manager and coach. Only those rules will be honored. You cannot make up ground rules as the game progresses. These ground rules must be filed with the league president before the schedule begins.

9:07 In tournament play all ground rules will be covered and agreed upon between coaches and umpires before each game.

9:12 If a player is injured by being hit with a batted ball in the face, throat or head, time will be called immediately and all players will be awarded one (1) base if injury to an infielder, two (2) bases if player injured was an outfielder. The awards are from the time of the pitch. Any other injury deemed serious enough in judgment of the umpire will be handled in the same manner. NOTE: THIS IS A JUDGMENT CALL AND CANNOT BE APPEALED OR PROTESTED.

9:14 6,7, and 8 year old World Series may be pool play, double elimination or a 3 game guarantee. A time limit is acceptable in pool play only. This must be approved by World Series Committee or National Commissioner.

9:17 If a batter squares to bunt and then swings, he will be called out (umpires decision).

10:00 TEAMS

10:04 All ages 5 thru 8 will be allowed eighteen (18) players whose names shall be registered with the league president by May 20th on league roster forms.

10:05 Managers may not sign new players after May 20th for ages 5 thru 8. A violation of this rule will make the player ineligible for tournament selections and reason for protest in local or tournament play.

11:00 ALL-STAR TOURNAMENT TEAMS

11:21 In all World Series and tournament play, in order for a game to become a complete game, it must be a full six (6) inning contest, regardless of the delay; and no other tournament game can be started until the completion of the interrupted game. All games shall be six (6) innings duration unless the losing manager wishes to concede without penalty. EXCEPTION: A game will be called when the opposing team has been numerically eliminated. This rule to apply in all local league play and all tournament play.

11:22 Teams may play more than two (2) games in one (1) day with the approval of the Dizzy Dean National State Executive Board.

11:24 District, State and World Series tournaments will be held each year. Each tournament will have three (3) separate age groups, (6U, 7U, and 8U).

11:25 Players may participate up in an older age group but will not be allowed to participate in a lower group. EXAMPLE: If a 7 year old plays in an 8-year-old league he may not drop down and play as a 7-year all-star. This does not count for a mixed league of 7 and 8 year olds combined.

11:26 A player must be a member of a franchised Dizzy Dean program and participate in half (1/2) of his teams scheduled games to be eligible for the all-star team.

11:27 All-star teams may have eighteen (18) players, (1) manager and three (3) coaches on the team. A team must field ten (10) players in tournament play at all times. PENALTY: FORFEIT.

20:00 OFFENSE

20:01 After one warning per game per player for slinging his bat, the batter will be out, a dead ball called, no runners advance.

20:17 In tournament play an offensive batter will receive five (5) pitches before being declared out. He will be called out on three (3) swinging strikes. If fifth (5th) pitch is fouled, he may continue to bat. If fifth (5th) pitch is fouled and caught it is an out. If the fifth (5th) pitch or 3rd strike is a bunted foul the batter is out.

20:18 Any base runner leaving the base before the ball reaches home plate is out (umpire's decision). The ball is dead and all other runners return to base occupied prior to pitch. The pitch will not count. If a runner misses a base it will be an appeal play to the umpire. (See appeals and protests.)

20:19 If a runner misses a base, it will be an appeal play to the umpire. (See appeals and protests.)

20:21 It is not an out in Farm League play age 5 & 6 for batter stepping on home plate. Delay dead ball and defense gets choice of play or re-bat.

20:22 There will be a maximum of seven (7) runs per inning per team.

21:00 DEFENSE

21:10 No rolling the ball intentionally will be allowed. No outs will be allowed by rolling the ball. Runners will automatically be safe if the defensive team rolls the ball. (Umpire's decision)

21:11 The infield fly rule will not be in effect.

21:12 Any base runner leaving the base before the ball reaches home plate is out (umpire's decision). The ball is dead and all other runners return to base occupied prior to pitch. The pitch will not count. If a runner misses a base, it will be an appeal play to the umpire. (See appeals and protests.)

21:13 Only ten (10) players on the field (four (4) outfielders).

21:14 The defensive player listed as pitcher will stay in the ten (10) foot circle until ball is hit. The player may have one foot outside of the circle. PENALTY: Offense gets choice of play or re-bat.

21:15 Play shall not be stopped by the defensive team heading off or stopping the front-runner. Any other runner may continue at his own risk. Any play made on a runner other than the front-runner will release the front-runner. Other runners may continue.

21:16 In league play if a team has less than ten (10) players, the manager may decide which position(s) to leave vacant on defense. EXCEPTION: Pitcher and catcher.

21:17 Five (5) and six (6) year old team may have two (2) coaches on defense and they must remain behind the outfielders until the play is over. PENALTY: Delay dead ball option to the offense when play is complete.

21:18 The defensive catcher must be in a direct line 10 feet behind home plate to make a play on a batted ball. PENALTY: Offensive team gets a choice of play or re-bat.

MINOR LEAGUE RULES

AGES 9-10

All coaches and leagues must try to get rule interpretations and problems solved by their state and national officers before contacting the Commissioner's office.

The Minor League division of Dizzy Dean Baseball, Inc. has been organized as a baseball program for youth whose 9th or 10th birthday falls before May first (1st) of the current year. Rules set forth in this book shall govern all tournament play. It is suggested that individual leagues follow these rules in local league play; however, they may be adapted to fit local league play at the option of each individual league.

1:00 THE PLAYING FIELD

These rules are mandatory for tournament play only.

1:03 First (1st) and third (3rd) baselines shall be sixty (60) feet from the point of home plate.

1:04 The distance from the point of home plate to second (2nd) base and from first (1st) base to third (3rd) base shall be (84) feet (10) inches.

1:05 The pitching distance from the point of home plate to the front of the rubber shall be forty-four (44) feet.

1:06 The minimum recommended home-run distance shall be 200 feet. Any new field should have an outfield fence of 210 feet.

1:07 The height of the pitching mound above the level of home plate shall be raised by gradual slope to a height of 6 inches.

1:08 The strike zone shall comply with major league rules.

2:00 EQUIPMENT

2:12 Metal cleats will not be allowed for participants (coaches, players, and umpires) twelve (12) years and under.

2:13 Catchers must wear shin guards, chest protector, cup and a protective helmet or plastic cap with or attached to the mask while on defense.

4:00 MANAGER & COACHES

4:06 Any manager who calls time and goes on to the playing field more than twice (2) in one inning per pitcher (not game) to talk to a player or players, will be required to remove the current pitcher. He may return to the mound after the side has been retired if eligible.

4:07 Any manager or coach going on to the playing field to talk to the same batter (or batter going to the dugout or bench to talk to a manager or coach) more than one (1) time per batter or three (3) times per inning will be required to remove the current batter from the game and make the substitution in the lineup. He may re-enter at completion of the inning if he can do so without violating the substitution rule. NOTE: The only exception to rule 4:06 and 4:07 is in case of injury, or if the time is called by the opposing team or the umpire.

5:00 REGULATION GAMES

5:01 In league play, it is a regulation game if it is called by the umpire due to darkness, rain or other cause which in the umpire's judgment interfered with further play, provided that (a) four (4) or more innings have been played, or (b) three and one half (3 1/2) innings shall constitute a legal game if the home team is ahead at the end of the half (1/2) inning, or before the end of the fourth (4th) inning if the home team is ahead (in the event of a partial inning beyond 4 innings revert back to the last complete inning). In the event that a game is halted before completion for any cause it must be resumed from the point of termination when the game is rescheduled by league officials with the same lineup as possible. EXCEPTION: If a team is leading its opponent by at least fifteen (15) runs at the end of the third (3rd) inning or ten (10) runs at the end of the fourth (4th) inning the game shall be terminated and the team in front declared the winner. This rule to apply in all local league play. WARNING: DO NOT VIOLATE ANY PITCHING RULES.

5:02 Games shall be six (6) innings in duration. In case of a tie at the end of the 6th inning of play the game shall go into extra innings until a winner is established or the game is called by the umpire.

6:00 PITCHING RULES-MINORS

6:06 A pitcher can pitch in consecutive games in the same day if he does not violate any of the following rules.

6:07 Any pitcher playing in the same game may return to the mound one time. If a game is delayed for any reason, he may be allowed to continue. WARNING: DO NOT VIOLATE ANY PITCHING RULE OR RE-ENTRY RULE.

6:08 An inning is interpreted to mean the following. If a pitcher pitches to one (1) batter and is removed from the pitching mound before he is retired, he is only charged with one-third (1/3) of an inning. If he is removed after retiring one (1) batter but after he has pitched to the next batter he is charged with two-thirds (2/3) of an inning. If he is removed after he has retired two (2) batters and has pitched one (1) pitch to the next batter, he is charged with one (1) complete inning.

6:09 If a pitcher pitches beyond his allotted innings per game, per day, per week or per tournament because of a double or triple play, there is no penalty. (He was legal when the pitch was made). The pitcher will be removed after the outs are made.

6:10 When a pitcher is turned in on a line-up card he is the pitcher of record and must dispose of a batter before he can be replaced or substituted for and he will be charged with a minimum of 1/3 of an inning. Any player who toes the rubber and takes a warm-up pitch to begin an inning will be the pitcher of record for that inning and be charged with a minimum of 1/3 of an inning, and he must dispose of a batter before he can be replaced or substituted for. (unless the pitcher is injured).

MINOR LEAGUE

6:11 A pitcher is allowed 8 innings each week.

6:12 A pitcher may pitch 12 innings in a tournament.

6:13 If any pitcher pitches three (3) full innings and then throws to another batter in the same game or day, he will not be eligible to pitch until he has had 48 hours rest, beginning with the time he leaves the pitching mound as a pitcher.

6:14 If a pitcher pitches no more than three (3) full innings in any day, he may be used on as many consecutive days as desired provided he does not exceed the 8 inning rule. (12 in tournament play).

6:15 A pitcher is limited to seven (7) innings in a game or day. No pitcher may pitch over seven (7) innings in a day. (DO NOT VIOLATE ANY PITCHING RULES) If a pitcher pitches one (1) pitch over three (3) innings, he will be required to rest for forty-eight (48) hours. If there is a second game in the same day, he will be ineligible to pitch if he has pitched over three (3) innings in his first game. If the game has been delayed until the next day and he has pitched more than three (3) innings, he will be required to rest forty-eight (48) hours before returning to the mound beginning at the time he left the mound. Under the re-entry substitute rule a pitcher may be replaced on the mound during any part of the game and return to the mound one (1) time. EXAMPLE: A pitcher may pitch and be replaced with a substitute and then return to the mound one time as a pitcher. See Common Rule 3:01 and 6:02. Applies to same game only. (Once a pitcher has pitched one pitch over three (3) innings and leaves the mound he may not return as a pitcher until he has had forty (48) hours rest.) (All pitching applies to that game regardless of the delay.)

6:16 If a pitcher, after coming in contact with the pitching rubber, with runner(s) on base, feints a throw to home plate, a balk will be called, with no one on base a ball will be called.

7:00 FORFEITURES, APPEALS AND PROTESTS

7:17 The umpire may call time-out for injury or protest. These time-outs will not be charged to a team.

7:18 An appeal play will be handled in this manner. The manager will make his appeal to the plate umpire who will consult the base umpire. The manager must identify the correct player by name or number and also the correct base involved in the play, no second chance if he names the wrong player or base. If he is correct, the base runner is out. Appeal must be made before the next pitch is thrown.

9:00 SPECIAL RULES

9:06 In league play all ground rules must be given on paper to the visiting manager and coach. Only those rules will be honored. You cannot make up ground rules as the game progresses. These ground rules must be filed with the league president before the schedule begins.

9:07 In tournament play all ground rules will be covered and agreed upon between coaches and umpires before each game.

9:11 Three (3) strikes is an out even if the ball is dropped.

9:12 Any base runner leaving the base before the ball reaches home plate is out (umpires decision). The ball is dead and all other runners return to base occupied prior to pitch. The pitch will not count. If a runner misses a base it will be an appeal play to the umpire. (See appeals and protests.)

9:13 Once the pitcher has possession of the ball and is in contact with the pitching rubber, any base runner who does not immediately advance to the next base or return to the previously occupied base is out (umpires decision). The ball is dead and no other runners may advance until the next pitched ball has crossed home plate. EXCEPTION: The runner is not out if a play is made on the runner (i.e., making a move toward the runner or faking a throw).

9:14 9 year old World Series may be pool play, double elimination or 3 game guarantee. A time limit is acceptable in pool play only. This must be approved by World Series Committee or National Commissioner.

10:00 TEAMS

10:04 All teams 9 and 10 will be allowed eighteen (18) players whose names shall be registered with the league president by May 20th.

10:05 Managers may not sign new players after May 20th for ages 9 and 10. A violation of this rule will make the player ineligible for tournament selections and reason for protest in local or tournament play.

19:00 TOURNAMENTS

19:20 (Minors) In all World Series and tournament play, in order for a game to become a complete game, it must be a full six (6) inning contest, regardless of the delay; and no other tournament game can be started until the completion of the interrupted game. All games shall be six (6) innings duration, unless the losing manager wishes to concede without penalty. EXCEPTION: if a team is leading its opponent by at least fifteen (15) runs at the end of the third (3rd) inning, or ten (10) runs at the end of the fourth (4th) inning, or any inning thereafter, the game shall be terminated and the team in front declared the winner in all tournament play. Refer to tournament rules, Common section 19:00.

FRESHMEN LEAGUE RULES

AGES 11-12

All coaches and leagues must try to get rule interpretations and problems solved by their state and national officers before contacting the commissioner's office.

The Freshmen League Division of Dizzy Dean Baseball, Inc. has been organized as a baseball program for youth whose 11th or 12th birthday falls before May first (1st) of the current year. Rules set forth in this book shall govern all tournament play. It is suggested that individual leagues follow these rules in local league play; however, they may be adapted to fit local league play at the option of each individual league.

1:00 THE PLAYING FIELD

1:03 First (1st) and third (3rd) baselines shall be seventy (70) feet from the point of home plate.

1:04 The distance from the point of home plate to second (2nd) base and from first (1st) base to third (3rd) base shall be ninety-nine (99) feet.

1:05 The pitching distance from the point of home plate to the front of the rubber shall be forty-nine (49) feet.

1:06 The minimum recommended home-run distance shall be 200 feet. The maximum shall be 250 feet. Any new field should have an outfield fence of 210 feet minimum.

1:07 The height of the pitching mound above the level of home plate shall be raised by gradual slope to a height of six (6) inches.

1:08 The strike zone shall comply with major league rules.

2:00 EQUIPMENT

2:12 Metal cleats will not be allowed for participants (coaches, players and umpires) twelve (12) years and under.

2:13 Catchers must wear shin guards, chest protector, cup and a protective helmet or plastic cap with or attached to the mask while on defense.

4:00 MANAGER & COACHES

4:06 Any manager who calls time and goes onto the playing field more than once in one (1) inning per pitcher (not game) to talk to a player or players, will be required to remove the current pitcher. He may return to the mound after the side has been retired if eligible.

4:07 Any manager or coach going on to the playing field to talk to the same batter (or a batter going to the dugout or bench to talk to a manager or coach) more than twice in one (1) time at bat will be required to remove the current batter from the game and make the substitution in the lineup. He may re-enter at completion of the inning if he can do so without violating the substitution rule. NOTE: The only exception to rule 4:06 and 4:07 is in case of injury or if the time is called by the opposing team or the umpire.

5:00 REGULATION GAMES

5:01 In league play, it is a regulation game if it is called by the umpire due to darkness, rain or other cause which in the umpire's judgment interfered with further play, provided that (a) four (4) or more innings have been played, or (b) three and one half (3 1/2) innings shall constitute a legal game if the home team is ahead at the end of the half (1/2) inning, or before the end of the fourth (4th) inning if the home team is ahead. In the event of a partial inning beyond 4 innings revert back to the last complete inning. In the event that a game is halted before completion for any cause it must be resumed from the point of termination when the game is rescheduled by league officials, with the same lineup as possible. EXCEPTION: If a team is leading its opponent by at least fifteen (15) runs at the end of the third (3rd) inning or ten (10) runs at the end of the fourth (4th) inning, the game shall be terminated and the team in front declared the winner. This rule to apply in all local league play. WARNING: DO NOT VIOLATE ANY PITCHING RULES.

5:02 Games shall be six (6) innings of duration. In case of a tie at the end of the 6th inning of play the game shall go into extra innings until a winner is established or the game is called by the umpire.

6:00 PITCHING RULES

6:06 A pitcher can pitch in consecutive games in the same day if he does not violate any of the following rules.

6:07 Any pitcher playing in the same ball game may return to the mound one (1) time. If a game is delayed for any reason, he may be allowed to continue.

WARNING: DO NOT VIOLATE ANY PITCHING RULES.

6:08 An inning is interpreted to mean the following: If a pitcher pitches to one (1) batter and is removed from the pitching mound before he is retired, he is only charged with pitching one-third (1/3) of an inning. If he is removed after retiring one (1) batter but after he has pitched to the next batter, he is charged with two-thirds (2/3) of an inning. If he is removed after he has retired two (2) batters and has pitched one (1) pitch to the next batter, he is charged with one (1) complete inning.

6:09 If a pitcher pitches beyond his allotted innings per game, per day, per week or per tournament because of a double or triple play, there is no penalty. (He was legal when the pitch was made). The pitcher will be removed after the outs are made.

6:10 When a pitcher is turned in on a line-up card he is the pitcher of record and must dispose of a batter before he can be replaced or substituted for and he will be charged with a minimum of 1/3 of an inning. Any player who toes the rubber and takes a warm-up pitch to begin an inning will be the pitcher of record for that inning and be charged with a minimum of 1/3 of an inning and he must dispose of a batter before he can be replaced or substituted for. (Unless the pitcher is injured).

FRESHMEN LEAGUE

6:11 A pitcher is allowed ten (10) innings each week.

6:12 A pitcher may pitch fourteen (14) innings in a tournament.

6:13 If any pitcher pitches three (3) full innings and then throws to another batter in the same game or day, he will not be eligible to pitch until he has had forty-eight (48) hours rest beginning with the time he leaves the pitching mound as a pitcher.

6:14 If a pitcher pitches no more than three (3) full innings in any day, he may be used on as many consecutive days as desired provided he does not exceed the ten (10) innings rule or fourteen (14) innings in tournament play.

6:15 A pitcher is limited to seven (7) innings in a game or day. No pitcher may pitch over seven (7) innings in a day. (DO NOT VIOLATE ANY PITCHING RULES.) If a pitcher pitches one (1) pitch over three (3) innings, he will be required to rest for forty-eight (48) hours. If there is a second game in the same day, he will be ineligible to pitch if he has pitched over three (3) innings in his first game. If the game has been delayed till the next day and he has pitched more than three (3) innings, he will be required to rest forty-eight (48) hours before returning to the mound beginning at the time he left the mound. Under the re-entry substitute rule a pitcher may be replaced on the mound during any part of the game and return to the mound one (1) time. EXAMPLE: A pitcher may pitch and be replaced with a substitute and then return to the mound one time as a pitcher. See Common Rule 3:01 and 6:02. Applies to same game only. (Once a pitcher has pitched one pitch over three (3) innings and leaves the mound he may not return as a pitcher until he has had forty (48) hours rest.) (All pitching applies to that game regardless of the delay.)

10:00 TEAMS

10:04 All teams 11 and 12 will be allowed eighteen (18) players whose names shall be registered with the league president by May 20th.

10:05 Managers may not sign new players after May 20th for ages 11 and 12. A violation of this rule will make the player ineligible for tournament selections and reason for protest in local or tournament play.

19:00 TOURNAMENTS

19:20 (Freshmen) In all World Series and tournament play in order for a game to become a complete game, it must be a full six (6) inning contest regardless of the delay; and no other tournament game can be started until the completion of the interrupted game. All games shall be six (6) innings duration unless the losing manager wishes to concede without penalty. EXCEPTION: If a team is leading its opponent by at least fifteen (15) runs at the end of the third (3rd) inning or ten (10) runs at the end of the fourth inning or any inning thereafter, the game shall be terminated and the team in front declared the winner in all tournament play. Refer to tournament rules, Common section 19:00.

**IF ANY PITCHER PITCHES BEYOND HIS ALLOTTED INNINGS
AND THEN THROWS TO ANOTHER BATTER
IN THE SAME GAME
OR DAY, HE WILL NOT BE ELIGIBLE TO PITCH
UNTIL HE HAS HAD 48 HOURS REST,
BEGINNING WITH THE TIME HE LEAVES
THE PITCHING MOUND AS A PITCHER.**

Common Rule Index

See Appropriate Age Group

Playing Field	Section 1:00
Equipment	Section 2:00
Re-Entry Substitution.....	Section 3:00
Manager and Coaches	Section 4:00
Regulation Game (S AAG).....	Section 5:00
Pitching Rules (S AAG).....	Section 6:00
Forfeiture, Appeals, and Protest.....	Section 7:00
Schedules.....	Section 8:00
Special Rules.....	Section 9:00
Teams	Section 10:00
All-Star Tournament Teams	Section 11:00
Player Eligibility	Section 12:00
Birth Certificates	Section 13:00
Player Registration	Section 14:00
Selection of Players.....	Section 15:00
League Registration	Section 16:00
Team Sponsor	Section 17:00
Admission To Games.....	Section 18:00
Tournaments.....	Section 19:00

*When a rule is not covered in these sections, refer to
Official Baseball Rules published by The Sporting News.*

SOPHOMORE LEAGUE RULES

AGES 13-14

All coaches and leagues must try to get rule interpretations and problems solved by their state and national officers before contacting the Commissioner's office.

The Sophomore League Division of Dizzy Dean Baseball, Inc. has been organized as a baseball program for youth whose 13th or 14th birthday falls before May first (1st) of the current year. Rules set forth in this book shall govern all tournament play. It is suggested that individual leagues follow these rules in local league play; however, they may be adapted to fit local league play at the option of each individual league.

In league play, you may double sanction 13-14 (Sophomore Division) and 15-16 (Junior Division). You can then play 13-16 year olds or any combination (Example: 13-15 year olds). You can then have a tournament team in each individual age group (Example: 13&under, 14&under, 15&under, 16&under). This also applies to 15-16 (Juniors) and 17-19 (Seniors). Under no circumstance can 13-14 (Sophomore) play with 17-19 (Senior).

1:00 THE PLAYING FIELD

1:03 First (1st) and third (3rd) baselines shall be eighty (80) feet from the point of home plate.

1:04 The distance from the point of home plate to second (2nd) base and from first (1st) base to third (3rd) base shall be one hundred thirteen (113) feet two (2) inches.

1:05 The pitching distance from the point of home plate to the front of the rubber shall be fifty-four (54) feet.

1:06 The minimum recommended home-run distance shall be 250 feet. Any new field should have an outfield fence of 300 feet minimum.

1:07 The height of the pitching mound above the level of home plate shall be raised by gradual slope to a height of ten (10) inches.

1:08 The strike zone shall comply with major league rules.

2:00 EQUIPMENT

2:12 Metal cleats will be allowed for participants (**coaches and players**) thirteen (13) years and up.

2:13 Catchers must wear shin guards, chest protector, cup, and a protective helmet or plastic cap with or attached to the mask while on defense.

4:00 MANAGER & COACHES

4:06 Any manager who calls time and goes onto the playing field more than once (1) in one (1) inning per pitcher (not game) to talk to a player or players will be required to remove the current pitcher. He may return to the mound after the side has been retired if eligible.

4:07 Any manager or coach going on to the playing field to talk to the same batter (or a batter going to the dugout or bench to talk to a manager or coach) more than twice in one (1) time at bat will be required to remove the current batter from the game and make the substitution in the lineup. He may re-enter at completion of the inning if he can do so without violating the substitution rule. NOTE: The only exception to rule 4:06 and 4:07 is in case of injury or if the time is called by the opposing team or the umpire.

5:00 REGULATION GAMES

5:01 In league play, it is a regulation game if it is called by the umpire due to darkness, rain or other cause which in the umpire's judgment interfered with further play, provided that (a) four (4) or more innings have been played, or (b) three and one half (3 1/2) innings shall constitute a legal game if the home team is ahead at the end of the half (1/2) inning, or before the end of the fourth (4th) inning if the home team is ahead. In the event of a partial inning beyond 4 innings revert back to the last complete inning. In the event that a game is halted before completion for any cause it must be resumed from the point of termination when the game is rescheduled by league officials with the same lineup as possible. EXCEPTION: If a team is leading its opponent by at least fifteen (15) runs at the end of the third (3rd) inning or ten (10) runs at the end of the fourth (4th) inning the game shall be terminated and the team in front declared the winner. This rule to apply in all local league play. WARNING: DO NOT VIOLATE ANY PITCHING RULES.

5:02 Games shall be seven (7) innings of duration. In the case of a tie at the end of seven (7) innings of play the game shall go into extra innings until a winner is established, or the game is called by the umpire.

6:00 PITCHING RULES

6:06 A pitcher can pitch in consecutive games in the same day if he does not violate any of the following rules.

6:07 Any pitcher playing in the same ball game may return to the mound one time. If a game is delayed for any reason, he may be allowed to continue. WARNING: DO NOT VIOLATE ANY PITCHING RULE OR RE-ENTRY RULE.

6:08 An inning is interpreted to mean the following: If a pitcher pitches to one (1) batter and is removed from the pitching mound before he is retired, he is only charged with pitching one-third (1/3) of an inning. If he is removed after retiring one (1) batter but after he has pitched to the next batter, he is charged with two-thirds (2/3) of an inning. If he is removed after he has retired two (2) batters and has pitched one (1) pitch to the next batter, he is charged with one (1) complete inning.

6:09 If a pitcher pitches beyond his allotted innings per game, per day, per week or per tournament because of a double or triple play there is no penalty. (He was legal when the pitch was made). The pitcher will be removed after the outs are made.

6:10 When a pitcher is turned in on a line-up card he is the pitcher of record and must dispose of a batter before he can be replaced or substituted for and he will be charged with a minimum of 1/3 of an inning. Any player who toes the rubber and takes a warm-up pitch to begin an inning will be the pitcher of record for that inning and be charged with a minimum of 1/3 of an inning and he must dispose of a batter before he can be replaced or substituted for. (Unless the pitcher is injured).

6:11 A pitcher is allowed twelve (12) innings each week.

6:12 A pitcher may pitch sixteen (16) innings in a tournament.

6:13 If any pitcher pitches four (4) full innings and then throws to another batter in the same game or day, he will not be eligible to pitch until he has had 36 hours rest,

SOPHOMORE LEAGUE

beginning with the time he leaves the pitching mound as a pitcher.

6:14 If a pitcher pitches no more than four (4) full innings in any day, he may be used on as many consecutive days as desired provided he does not exceed the 12 inning rule. (16 in tournament play).

6:15 A pitcher is limited to ten (10) innings in a game or day. No pitcher may pitch over ten (10) innings in a day. (DO NOT VIOLATE ANY PITCHING RULES.) If a pitcher pitches one (1) pitch over four (4) innings, he will be required to rest for thirty-six (36) hours. If there is a second game in the same day, he will be ineligible to pitch if he has pitched over four (4) innings in his first game. If the game has been delayed till the next day and he has pitched more than four (4) innings, he will be required to rest thirty-six (36) hours before returning to the mound beginning at the time he left the mound. Under the re-entry substitute rule a pitcher may be replaced on the mound during any part of the game and return to the mound one (1) time. The pitcher may return to the mound after the side has been retired if eligible. EXAMPLE: A pitcher may pitch and be replaced with a substitute and then return to the mound one time as a pitcher. See Common Rule 3:01 and 6:02. Applies to same game only. (Once a pitcher has pitched one pitch over four (4) innings and leaves the mound he may not return as a pitcher until he has had thirty-six (36) hours rest.) (All pitching applies to that game regardless of the delay.)

9:00 SPECIAL RULES

9:15 A designated hitter will be allowed for any player in the Sophomore League.

9:16 A hitter may be (not mandatory) designated for any one starting player (not just pitchers) and all subsequent substitutes for that player in the game. A starting defensive player cannot be listed as the designated hitter in the starting lineup. A designated hitter for said player shall be selected prior to the start of the game and his name shall be included on the lineup cards presented to the umpire-in-chief and to the official scorer. Failure to declare a designated hitter prior to the game precludes the use of a designated hitter in that game. If a pinch hitter or pinch runner for the designated hitter is used, that player becomes the new designated hitter. The player who was the designated hitter may re-enter as the designated hitter under the re-entry rule. A designated hitter and the player for whom he is batting are locked into the batting order. No multiple substitutions may be made that will alter the batting rotation. The role of the designated hitter is terminated for the remainder of the game when:

- a.) the defensive player, or any previous defensive player for whom the designated hitter batted, subsequently bats, pinch-hits, or pinch-runs for the designated hitter; or
- b.) the designated hitter or any previous designated hitter assumes a defensive position.

10:00 TEAMS

10:04 All teams 13 thru 14 will be allowed eighteen (18) players, whose names shall be registered with the league president by June 1st.

10:05 Managers may not sign new players after June 1st for ages 13 and 14. A violation of this rule will make the player ineligible for tournament selection and a reason for protest in local or tournament play.

10:06 All players must be registered with the league president by June 1st. A violation of this rule will make the player/players ineligible for tournament team/all-star team selection and reason for protest in local league and tournament play.

10:07 A manager may franchise a complete roster independent of a player selection system. NOTE: This team cannot add any players after their team Certificate of Entry is submitted and must play at least a twelve (12) game schedule interlocking with other sanctioned Dizzy Dean Baseball teams selected the same way.

10:08 Teams formed independent of a player selection system cannot add any player(s) for the purpose of tournament play. (These teams cannot add any player to their June 1st roster).

19:00 TOURNAMENTS

19:20 In all World Series and tournament play, in order for a game to become a complete game, it must be a full seven (7) inning contest regardless of the delay; and no other tournament game can be started until the completion of the interrupted game. All games shall be seven (7) innings duration unless the losing manager wishes to concede without penalty. Exception: If a team is leading its opponent by at least (15) runs at the end of the fourth (4th) inning or ten (10) runs at the end of the fifth (5th) inning or any inning thereafter, the game shall be terminated and the team in front declared the winner in all tournament play. Refer to tournament rules, Common section 19:00.

JUNIOR & SENIOR LEAGUE

AGES 15-16-17-18-19

All coaches and leagues must try to get rule interpretations and problems solved by their state and national officers before contacting the Commissioner's office.

The Junior Division of Dizzy Dean Baseball, Inc. has been organized as a baseball program for youth whose 15th and 16th birthday falls before May first (1st) of the current year. The Senior Division is for youth whose 17th, 18th or 19th birthday falls before August first (1st) of the current year. Rules set forth in this book shall govern all tournament play. It is suggested that individual leagues follow these rules in local league play; however, they may be adapted to fit local league play at the option of each individual league.

1:00 THE PLAYING FIELD

1:03 First (1st) and third (3rd) baselines shall be ninety (90) feet from the point of home plate.

1:04 The distance from the point of home plate to second (2nd) base and from first (1st) base to third (3rd) base shall be one hundred twenty-seven (127) feet three and three eights (3-3/8) inches.

1:05 The pitching distance from the point of home plate to the front of the rubber shall be sixty (60) feet six (6) inches.

1:06 The minimum recommended home-run distance shall be 300 feet. Any new field should have an outfield fence of 300 feet minimum.

1:07 The height of the pitching mound above the level of home plate shall be raised by gradual slope to a height of ten (10) inches.

1:08 The strike zone shall comply with major league rules.

2:00 EQUIPMENT

2:12 Metal cleats will be allowed for participants (**coaches and players**) fifteen (15) years and up.

2:13 Catchers must wear shin guards, chest protector, cup and a protective helmet or plastic cap with or attached to the mask while on defense.

2:14 Each bat shall be: In diameter...at thickest part 2 5/8 inches or less. In length...36 inches or less. In weight...A bat shall not weigh numerically more than three ounces less than the length of the bat (e.g..., a 33 inch long bat cannot be less than 30 ounces).

4:00 MANAGER & COACHES

4:06 Any manager who calls time and goes onto the playing field more than once (1) in one (1) inning per pitcher (not game) to talk to a player or players will be required to remove the current pitcher. He may return to the mound after the side has been retired if eligible.

4:07 Any manager or coach going on to the playing field to talk to the same batter (or a batter going to the dugout or bench to talk to a manager or coach) more than twice (2) in one (1) time at bat will be required to remove the current batter from the game and make the substitution in the lineup. NOTE: The only exception to rule 4:06 and 4:07 is in case of an injury or if the time is called by the opposing team or the umpire.

5:00 REGULATION GAMES

5:01 In league play, it is a regulation game if it is called by the umpire due to darkness, rain or other cause which in the umpire's judgment interfered with further play, provided that (a) four (4) or more innings have been played, or (b) three and one half (3 1/2) innings shall constitute a legal game if the home team is ahead at the end of the half (1/2) inning or before the end of the fourth (4th) inning if the home team is ahead. In the event of a partial inning beyond 4 innings revert back to the last complete inning. In the event that a game is halted before completion for any cause it must be resumed from the point of termination when the game is rescheduled by league officials with the same lineup as possible. EXCEPTION: If a team is leading its opponent by at least fifteen (15) runs at the end of the third (3rd) inning or ten (10) runs at the end of the fourth (4th) inning the game shall be terminated and the team in front declared the winner. This rule to apply in all local league play. WARNING: DO NOT VIOLATE ANY PITCHING RULES.

5:02 Games shall be seven (7) innings of duration. In the case of a tie at the end of seven (7) innings of play the game shall go into extra innings until a winner is established or the game is called by the umpire.

6:00 PITCHING RULES

6:06 A pitcher can pitch in consecutive games in the same day if he does not violate any of the following rules.

6:07 Any pitcher playing in the same ball game may return to the mound one (1) time. If a game is delayed for any reason, he may be allowed to continue.

WARNING: DO NOT VIOLATE ANY PITCHING RULE OR RE-ENTRY RULE.

6:08 An inning is interpreted to mean the following: If a pitcher pitches to one (1) batter and is removed from the pitching mound before he is retired, he is only charged with pitching one-third (1/3) of an inning. If he is removed after retiring one (1) batter but after he has pitched to the next batter, he is charged with two-thirds (2/3) of an inning. If he is removed after he has retired two (2) batters and has pitched one (1) pitch to the next batter, he is charged with one (1) complete inning.

6:09 If a pitcher pitches beyond his allotted innings per game, per day, per week or per tournament because of a double or triple play there is no penalty. (He was legal when the pitch was made). The pitcher will be removed after the outs are made.

6:10 When a pitcher is turned in on a line-up card he is the pitcher of record and must dispose of a batter before he can be replaced or substituted for, and he will be charged with a minimum of 1/3 of an inning. Any player who toes the rubber and takes a warm-up pitch to begin an inning will be the pitcher of record for that inning and be charged with a minimum of 1/3 of an inning and he must

JUNIOR & SENIOR

dispose of a batter before he can be replaced or substituted for. (Unless the pitcher is injured).

6:11 A pitcher is allowed fourteen (14) innings each week.

6:12 A pitcher is allowed eighteen (18) innings is a tournament.

6:13 If any pitcher pitches four (4) full innings and throws to another batter in the same game or day, he will not be eligible to pitch until he has twenty-four (24) hours of rest beginning with the time he leaves the mound as a pitcher.

6:14 If a pitcher pitches no more than four (4) innings in any day, he may be used on as many consecutive days as desired provided he does not exceed the fourteen (14) innings rule. (18 in tournament play)

6:15 A pitcher is limited to ten (10) innings in a game or day. No pitcher may pitch over ten (10) innings in a day. (DO NOT VIOLATE ANY PITCHING RULES.) If a pitcher pitches one (1) pitch over four (4) innings, he will be required to rest for twenty-four (24) hours. If there is a second game in the same day, he will be ineligible to pitch if he has pitched over four (4) innings in his first game. If the game has been delayed until the next day and he has pitched more than four (4) innings, he will be required to rest twenty-four (24) hours before returning to the mound beginning at the time he left the mound. Under the re-entry substitute rule a pitcher may be replaced on the mound during any part of the game and return to the mound one (1) time. The pitcher may return to the mound after the side is retired if eligible. EXAMPLE: A pitcher may pitch and be replaced with a substitute and then return to the mound one time as a pitcher. See Common Rule 3:01 and 6:02. Applies to same game only. (Once a pitcher has pitched one pitch over four (4) innings and leaves the mound he may not return as a pitcher until he has had twenty-four (24) hours rest.) (All pitching rules apply to that game regardless of the delay.)

9:00 SPECIAL RULES

9:15 A designated hitter will be allowed for any player in the Junior and Senior programs.

10:00 TEAMS

10:04 All teams 15 thru 19 will be allowed eighteen (18) players whose names shall be registered with the league president by June 1st.

10:05 Managers may not sign new players after June 1st for ages 15 thru 19 and High School. A violation of this rule will make the player ineligible for tournament selection and a reason for protest in local or tournament play.

19:00 TOURNAMENTS

19:20 (Junior & Senior) In all World Series and tournament play, in order for a game to become a complete game, it must be a full seven (7) inning contest, regardless of the delay; and no other tournament game can be started until the completion of the interrupted game. All games shall be seven (7) innings duration unless the losing manager wishes to concede without penalty. Exception: If a team is leading its opponent by at least (15) runs at the end of the fourth (4th) inning or ten (10) runs at the end of the fifth (5th) inning or any inning thereafter, the game shall be terminated and the team in front declared the winner in all tournament play. Refer to tournament rules, Common section 19:00.

**IF ANY PITCHER PITCHES FOUR (4) FULL INNINGS
AND THEN THROWS TO ANOTHER BATTER
IN THE SAME GAME
OR DAY, HE WILL NOT BE ELIGIBLE TO PITCH
UNTIL HE HAS HAD 24 HOURS REST,
BEGINNING WITH THE TIME HE LEAVES
THE PITCHING MOUND AS A PITCHER.**

Dizzy Dean Baseball, Inc.

HIGH SCHOOL DIVISION

Creating a High School Division for high school programs complete through District, State and World Series Play. This program will be played under the National Federation of State High School Associations rules with the following exceptions.

PLAYER SELECTION AND TEAM SELECTION OF PLAYERS

All Players on a team must come from the same high school and be enrolled at that high school the last quarter of the school year. They must be eligible to return as high school players the following year. No incoming freshmen will be eligible unless they are coming from a feeder school for that high school district. If no feeder school is available for that district, no freshmen will be eligible for that team. Any player transferring from another school must show proper proof of transfer and be approved by the National State Executive Board.

6:00 PITCHING RULES

6:06 A pitcher can pitch in consecutive games in the same day if he does not violate any of the following rules.

6:07 Any pitcher playing in the same ball game may return to the mound one (1) time. If a game is delayed for any reason, he may be allowed to continue. **WARNING: DO NOT VIOLATE ANY PITCHING RULE OR RE-ENTRY RULE.**

6:08 An inning is interpreted to mean the following: If a pitcher pitches to one (1) batter and is removed from the pitching mound before he is retired, he is only charged with pitching one-third (1/3) of an inning. If he is removed after retiring one (1) batter but after he has pitched to the next batter, he is charged with two-thirds (2/3) of an inning. If he is removed after he has retired two (2) batters and has pitched one (1) pitch to the next batter he is charged with one (1) complete inning.

6:09 If a pitcher pitches beyond his allotted innings per game, per day, per week or per tournament because of a double or triple play there is no penalty. (He was legal when the pitch was made). The pitcher will be removed after the outs are made.

6:10 When a pitcher is turned in on a line-up card he is the pitcher of record and must dispose of a batter before he can be replaced or substituted for and he will be charged with a minimum of 1/3 of an inning. Any player who toes the rubber and takes a warm-up pitch to begin an inning will be the pitcher of record for that inning and be charged with a minimum of 1/3 of an inning and he must dispose of a batter before he can be replaced or substituted. (Unless the pitcher is injured).

6:11 A pitcher is allowed fourteen (14) innings each week.

6:12 A pitcher is allowed eighteen (18) innings in a tournament.

6:13 If any pitcher pitches four (4) full innings and throws to another batter in the same game or day, he will not be eligible to pitch until he has twenty-four (24) hours of rest beginning with the time he leaves the mound as a pitcher.

6:14 If a pitcher pitches no more than four (4) innings in any day, he may be used on as many consecutive days as desired provided he does not exceed the fourteen (14) innings rule. (18 in tournament play)

6:15 A pitcher is limited to ten (10) innings in a game or day. No pitcher may pitch over ten (10) innings in a day. (DO NOT VIOLATE ANY PITCHING RULES.) If a pitcher pitches one (1) pitch over four (4) innings, he will be required to rest for twenty-four (24) hours. If there is a second game in the same day, he will be ineligible to pitch if he has pitched over four (4) innings in his first game. If the game has been delayed until the next day and he has pitched more than four (4) innings, he will be required to rest twenty-four (24) hours before returning to the mound beginning at the time he left the mound. Under the re-entry substitute rule a pitcher may be replaced on the mound during any part of the game and return to the mound one (1) time. The pitcher may return to the mound after the side is retired if eligible. EXAMPLE: A pitcher may pitch and be replaced with a substitute and then return to the mound one time as a pitcher. See Common Rule 3:01 and 6:02. Applies to same game only. (Once a pitcher has pitched one pitch over four (4) innings and leaves the mound he may not return as a pitcher until he has had twenty-four (24) hours rest.) (All pitching applies to that game regardless of the delay.)

10:00 TEAMS

10:04 All High School teams will be allowed eighteen (18) players.

TOURNAMENT FORMAT

A State Tournament and District Tournament (if necessary) will be offered as a double elimination tournament. This will be followed by a World Series played under the Round Robin Format.

(A) There will be a two hundred dollar (\$200.00) entry fee payable to the host site.

(B) Teams will be scheduled a minimum of four (4) games pool play.

(C) Pool winners will advance to championship games for World Title.

(D) Senior Division rule of no more than two (2) games in one day does not apply in the pool play format (In district and state play the rule is still in effect).

(E) Senior Division pitching rules are in effect.

(F) The pool winner will be decided by:

HIGH SCHOOL

Best Record

Head to Head Competition

Runs Allowed

Runs Differential

Runs Scored

Coin Toss

General Rules

All rules not covered under these or the Senior Division rules will be covered under the American League Rules of Major League Baseball.

Notes:

- (A) High School re-entry rule in effect.
- (B) No player may be selected for more than one (1) tournament team.
- (C) No all-star teams with other teams in your league will be allowed (see player selection)
- (D) Any rules not covered see State or National Director for clarification.
- (E) Each bat shall be: In diameter... at the thickest part 2 5/8 inches or less. In length...36 inches or less. In weight... A bat shall not weigh numerically more than three ounces less than the length of the bat (i.e., a 33 inch bat cannot weigh less than 30 ounces).
- (F) All teams participating in tournament play will be required to wear the Dizzy Dean Patch attached in a manner not to appear temporary and located in the same place on all jerseys (either shoulder or breast pocket). PENALTY: Violators will not be allowed to play.

**IF ANY PITCHER PITCHES FOUR (4) FULL INNINGS
AND THEN THROWS TO ANOTHER BATTER
IN THE SAME GAME
OR DAY, HE WILL NOT BE ELIGIBLE TO PITCH
UNTIL HE HAS HAD 24 HOURS REST,
BEGINNING WITH THE TIME HE LEAVES
THE PITCHING MOUND AS A PITCHER.**